

USN

--	--	--	--	--	--	--	--	--	--

17CIV13/23

## First/Second Semester B.E. Degree Examination, July/August 2022 Elements of Civil Engineering and Mechanics

Time: 3 hrs.

Max. Marks: 100

**Note: Answer any FIVE full questions, choosing ONE full question from each module.**

### Module-1

- 1 a. Explain briefly the scope of the following Civil Engineering fields :
  - i) Environmental Engineering (10 Marks)
  - ii) Transportation Engineering. (05 Marks)
- b. Explain Force with its characteristics. (05 Marks)
- c. Replace 600N horizontal force acting on the lever by and equivalent system consisting of a force and couple at 'O'. [Refer Fig. Q1(c)]. (05 Marks)

Fig. Q1(c)

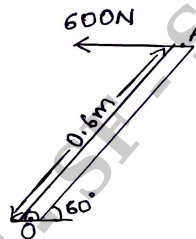

**OR**

- 2 a. Explain the types of dams according to their structural behaviour. (08 Marks)
- b. Explain the principle of Transmissibility of Forces. (04 Marks)
- c. Determine the angle ' $\alpha$ ' for which the moment of 500N force shown in Fig. Q2(c) is maximum about 'O'. Also find the maximum moment. (08 Marks)

Fig. Q2(c)

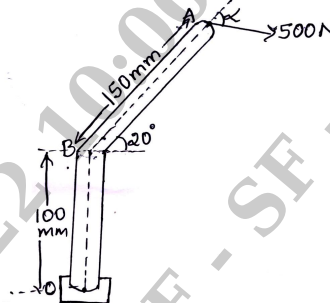

### Module-2

- 3 a. State and prove Lami's theorem. (05 Marks)
- b. The sum of 2 concurrent forces P and Q is 500N and their resultant is 400N. If the resultant is perpendicular to P, find P, Q and angle between P and Q. (10 Marks)
- c. Find the tension in the string and reaction at contact surface of cylinder of weight 1000N placed as shown in Fig. Q3(c) by using Lami's theorem. (05 Marks)

Fig. Q3(c)

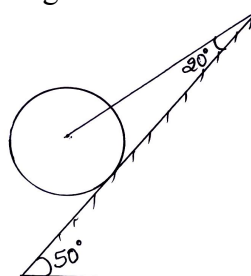

OR

- 4 a. Explain Free body diagram with examples. (04 Marks)  
 b. What is the value of P in the system shown in Fig. Q4(b) to cause the motion to impend? Assume the pulley is smooth and co-efficient of friction for all contact surfaces is 0.2. (08 Marks)

Fig. Q4(b)

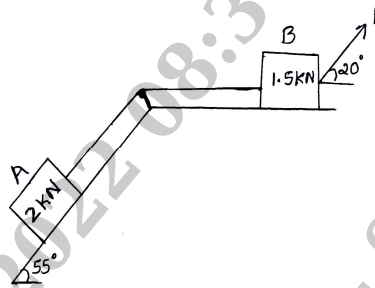

- c. Determine the force F and its inclination  $\alpha$  required so as to lift a block of weight 500N as shown in Fig. Q4(c). (08 Marks)

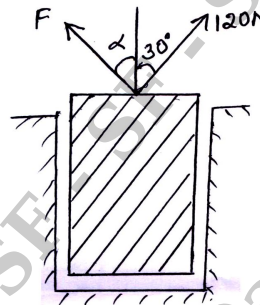
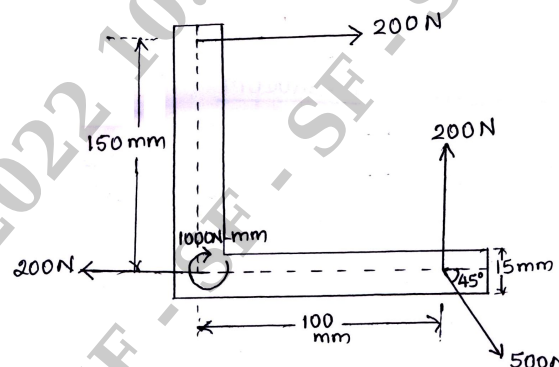

Fig. Q4(c)

**Module-3**

- 5 a. Explain the types of supports and types of loads with neat sketch. (08 Marks)  
 b. Determine the magnitude, direction and position of the resultant of forces as shown in Fig. Q5(b). Also find the X and Y intercepts of resultant force with respect to 'O'. (12 Marks)

Fig. Q5(b)



OR

- 6 a. State and prove Varignon's theorem of Moment. (06 Marks)  
 b. Determine the distance 'X' of the load 'P' from the support A if the reaction at A is twice as greater as reaction as B. Take P = 2kN and Q = 1 kN. (06 Marks)

Fig. Q6(b)

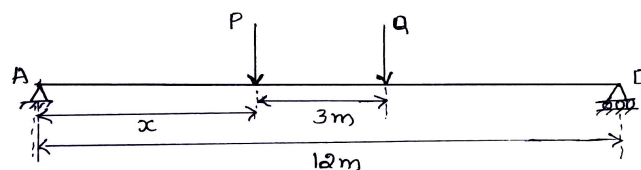

- c. Determine the reactions at A and B for the beam as shown in Fig. Q6(c). **(08 Marks)**

Fig. Q6(c)

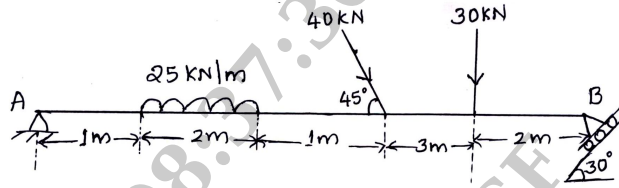

**Module-4**

- 7 a. Determine the centroid of quarter circle of radius R by the method of Integration. **(08 Marks)**  
 b. Determine the Polar radius of Gyration of the area shown in Fig. Q7(b). **(12 Marks)**

Fig. Q7(b)

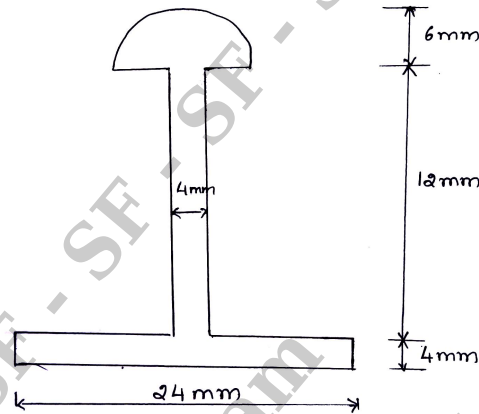

**OR**

- 8 a. Determine the moment of inertia of triangle by the method of Integration. **(08 Marks)**  
 b. State and prove Perpendicular Axis theorem. **(04 Marks)**  
 c. For a shaded area shown in Fig. Q8(c), find 'a' so that centroid is at 'O'. **(08 Marks)**

Fig. Q8(c)

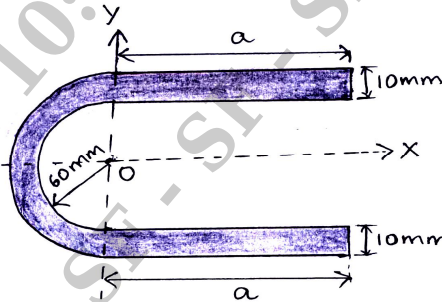

**Module-5**

- 9 a. A small steel ball is shot vertically upwards from the top of a building 25m above the ground with an initial velocity of 18m/sec.  
 i) In what time, it will reach the maximum height?  
 ii) How high above the building will the ball rise?  
 iii) Compute the velocity with which it will strike the ground and the total time it is in motion. **(10 Marks)**  
 b. What is Projectile? Define the following terms briefly :  
 i) Angle of projection  
 ii) Horizontal range      iii) Vertical height      iv) Time of flight. **(10 Marks)**

**OR**

- 10 a. The motion of a particle moving in a straight line is given by the expression  

$$S = t^3 - 3t^2 + 2t + 5$$
 Where, S is displacement in meters and t is time in seconds. Determine  
 i) Velocity and acceleration after 4 secs.  
 ii) Maximum / minimum velocity and corresponding displacement.  
 iii) Time at which velocity is zero. (10 Marks)
- b. Determine the position at which a ball thrown up the plane will strike the inclined plane as shown in Fig. Q10(b). The initial velocity is 30m/sec and angle of projection is  $\tan^{-1} \left[ \frac{4}{3} \right]$  with horizontal. (10 Marks)

Fig. Q10(b)

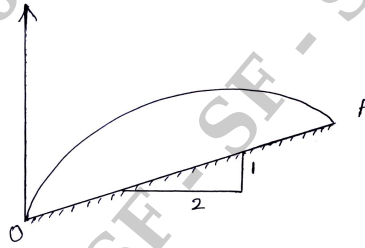

\* \* \* \* \*